

GALILEO | GALILEO RESEARCH

A true Revolution in the world
of Gyrotory Compaction



It's Radically Different

The completely new Galileo range represents a true Copernican Revolution* in the field of Gyrotory Compaction. It incorporates innovations that will create a paradigm shift and completely changes the established Status Quo.

Sophisticated engineering with Electromechanical Servoactuation technology and "Orbital" system

A robust, precision-engineered steel structure, incorporating the Electromechanical Servoactuation (EmS) mechanism for vertical load application and "Orbital" proprietary gyration and mould rotation system (patent pending) which delivers highly accurate and repeatable test results, together with stiffness and angle stability values that fall comfortably within the limits defined in EN 12697-31. The large user-friendly integrated color touch screen control panel shows the test graph in real time.

A global system with multi-lingual software

The on-board firmware includes nine languages and also offers the option to control the tests from a PC. The language can similarly be defined in the PC software, making the systems easily configurable to local user needs.

Designed with your needs in mind

Two versions on offer: Galileo and Galileo Research. The Galileo Research version is supplied complete with Shear measurement system, PC software for data analysis and motorized integrated extruder. Both models are equipped with a motorized mould lifting, height calibration tool and come with an operating instruction and traceable ACCREDIA certificate conforming ASTM & AASHTO Standards. An optional certificate conforming EN Standards is also available.*

Also available as options are an integrated balance, cylinder moulds, distance plates and ILS calibration device

→ Refer to the Accessories Section page 9.

* CONTROLS S.p.A. is accredited as Calibration Centre LAT 092 for the calibration and verification of force transfer on compression machines in accordance to EN 12390-4:2000 and EN-ISO7500-1:2018.

ACCREDIA is a signatory of the ILAC-MRA (International Laboratory Accreditation Cooperation - Mutual Recognition Arrangement), meaning calibration certificates with the Accredia mark are recognized and valid worldwide.

The accreditation bodies that are signatories to the ILAC MRA for the relevant accreditation activities will accept the results of each other's accredited laboratories and inspection bodies and programs provided by PTPs (Proficiency Testing Providers).

Nicolaus Copernicus



Before Galileo, Copernicus was the first to put the sun at the centre of the planets orbital rotation and "Orbital" is the patented system at the heart of Galileo Gyrotory Compactors. They innovatively combine the patented Orbital mechanism with IPC Global's ground-breaking Electromechanical Servoactuation (EmS) technologies to create a truly innovative solution.

* The Copernican Revolution was the paradigm shift from the Ptolemaic model of the heavens, which described the cosmos as having Earth stationary at the centre of the universe, to the heliocentric model with the Sun at the centre of the Solar System.

Unparalleled Benefits

The Galileo Gyrotory Compactors represent the most evolved models currently available on the market, worldwide. It has been made available in two versions: Galileo and Galileo Research.



Galileo



Flexible & convenient

- User defined closed-loop control of rate of gyration and axial load.
- Easy installation with single-phase power.
- Quick, simple and low maintenance from total electro-mechanical system including Electro-mechanical Servoactuation (EmS).



Efficient & productive

- Simultaneous compaction and extrusion of previous specimen.
- Quick, easy and clear adjustments with color 7" 16:9 control panel.
- Ultimate convenience with integrated extruder and balance (optional).
- Continuous Shear Stress measurement (optional).



Safe

- Inter-locked safety screen.
- Easy mould insertion on low friction surfaces.
- Automatic mould lift function.
- Orbital systems that allows for light yet hardy moulds.



Highly accurate

- Precision engineered, extremely rigid frame and robust loading mechanism for high accuracy and long life.
- Ultimate parallelism with unique recirculating-ball linear guides.
- Superior load control from piston mounted load-cell.
- Sensorless vectorial inverter for mould rotation.

Galileo Research



Flexible & convenient



Safe



Efficient & productive



Highly accurate

In addition to the Galileo Standard's benefits, Galileo Research also includes the following benefits:



Allows total flexibility with user defined closed-loop control of gyrotory angle.



Totally parallel sample faces with zero-angle test-end function.



Automatic results and data saving on PC or USB plus Windows data analysis and processing.

Fully Electromechanical

GALILEO

Fully Electromechanical – No Compressed Air Required

- High precision, robust loading mechanism combined with an extremely rigid frame assures high accuracy and repeatability.
- Load cell fitted directly on the vertical actuator for accurate load measurement and feedback control.
- Quick and easy manual / mechanical adjustment of the gyratory angle; shown on the display.
- User defined axial stress and speed of rotation.
- Sliding transparent door with safety interlock.
- Catch tray to collect expelled liquids when using perforated moulds.
- Fresh concrete configuration available.



- Easy control using the integrated 7" color touchscreen control panel or connected PC.
- User friendly PC software (optional) for data analysis and test set-up. Remote communication is available to receive immediate diagnostics.
- Automatic data saving on USB or on Windows PC.
- Lightweight yet robust moulds strictly comply with international standards.
- Safe and easy mould insertion and extraction with automatic lifting ensures low effort for the operator and higher productivity.
- Simultaneous extraction of last specimen while compacting the next specimen for higher productivity.
- Easy specimen extraction with the integrated extruder (optional).



Safe and easy mould insertion and extraction with automatic lifting ensures low effort for the operator. The simultaneous extraction of last specimen while compacting the next specimen delivers high levels of productivity.

GALILEO RESEARCH

Fully Electromechanical – No Compressed Air Required

In addition to the Galileo model's unique features, Galileo Research includes exclusive features below:

- Perfect gyratory angle with real-time closed loop automatic angle adjustment for compliance compensation.
- Easy and accurate motorized regulation of the gyratory angle displayed and set from the control panel.
- User defined gyratory angle with the possibility to define custom test patterns.
- Possibility to automatically obtain a zero-angle at the end of the test.
- Real-time direct shear and torque resistance measurement. Automatic calculation of the compaction energy, a very important parameter for Research (optional for Galileo).

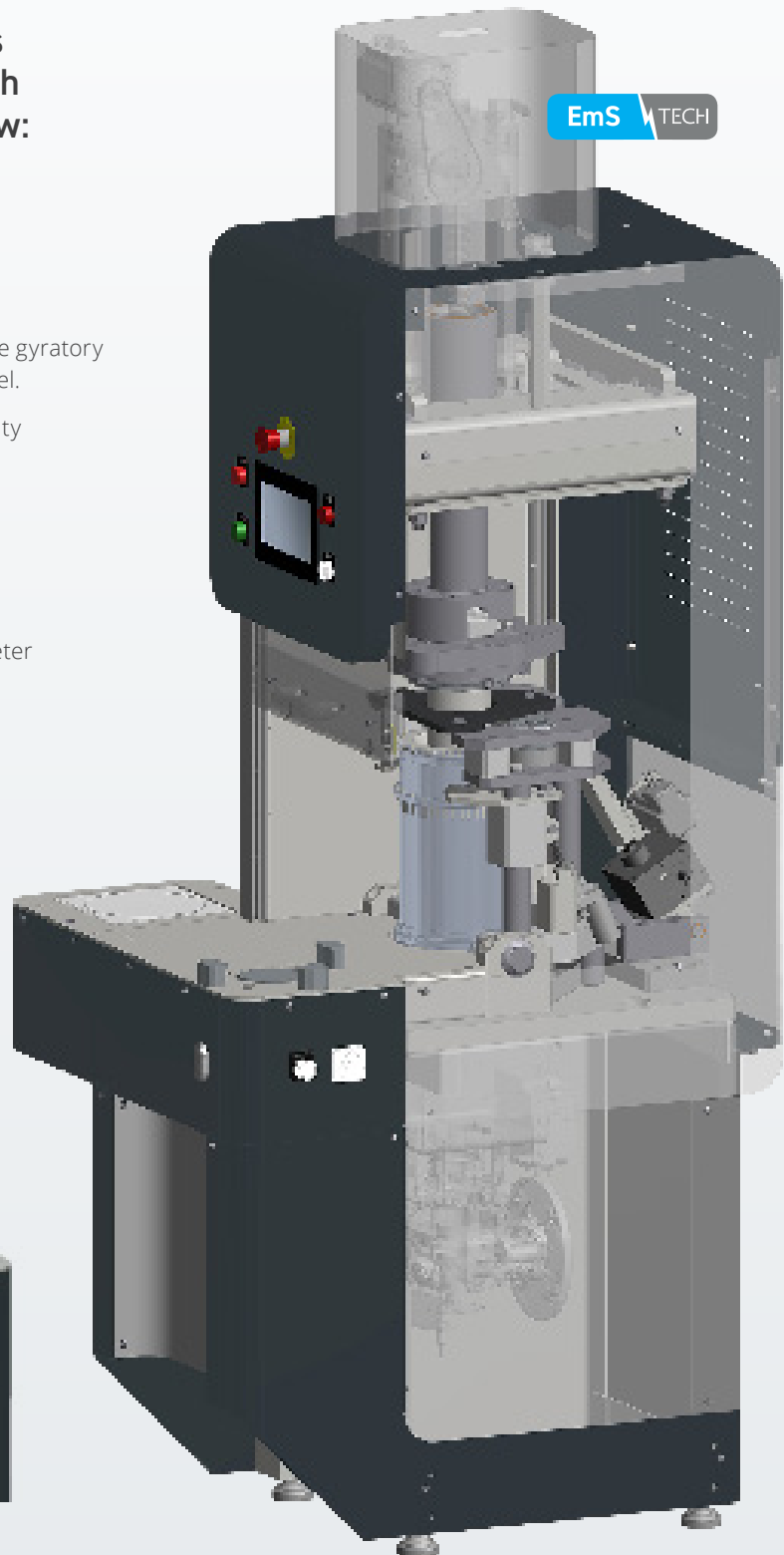
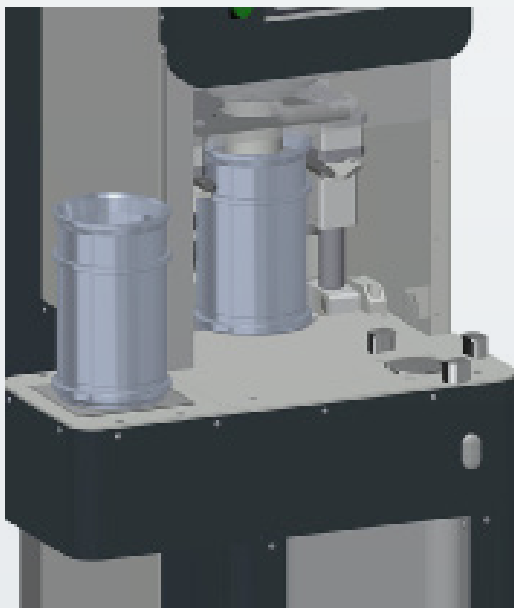

Truly Innovative

A resilient Testing System that incorporates the use of the Electromechanical Servoactuation mechanism, a Smart Control Panel and unique Orbital system.

Electromechanical Servoactuation Technology (EmS) EmS TECH

Galileo gyratory compactors benefit from IPC Global's new Electromechanical Servoactuation technology. Environmentally friendly and clean to operate, EmS technology requires no compressed air or hydraulic oil. Extremely reliable and accurate, the Galileo's intuitive design ensures it can be quickly and easily maintained.

EmS Components

Vertical load application system, including:

- Loading by high performance motor, able to deliver 17kN.
- Direct load measurement by load cell.
- Horizontal recirculating-ball linear guides for the upper carriage, enabling a high precision parallelism factor between upper and lower plates, far exceeding the limits of relevant standards.
- Sophisticated PID closed-loop load control, ensuring load is reached fast, smoothly and accurately and then maintained with precision throughout the test within 2% of every gyration (far exceeding relevant standards). The load cell feedback allows high load accuracy from very low loads, making Galileo suitable for special applications, like fresh concrete compaction. This performance is not possible with traditional indirect measuring systems such as pressure transducers.

The closed-loop angle set-up and control system mean that the gyratory angle can be set at the start of the test and be maintained constant at a fixed angle (between 0° and 3°) throughout the test, with precision and accuracy unachievable by traditional systems that use open-loop mechanical adjustment of the angle. The electronic control allows the user to set the automatic mould return to 0° at the end of compaction, to obtain specimens with perfect perpendicularity between the parallel faces and the cylindrical surface.

Smart Control

Galileo systems include a smart controller with a wide 7" 16:9 color Control Panel and Ethernet communications port for direct remote communication via the intranet or internet for connection with and immediate diagnostic analysis from manufacturer. Both Windows PC and Control Panel interfaces allow for user input of test parameters and will display and plot either height, density, angle, load, shear stress (optional) and compaction energy (only with optional shear measurement) against gyratory cycles in real time.

→ **More details can be found on page 8**



Orbital Motion (patent pending)

Orbital is the unique and ingenious (patent pending) system at the heart of Galileo Gyrotory compactors, based on the elementary resolution of the gyrotory motion conforming, to use a well known example, to the Galileo theory that the earth rotates around the sun "eppur si muove..." yet it moves.

How it works

The ORBITAL system is characterized by the rotation of the mould around its inclined axis and the micrometrical adjustment of the gyrotory angle from 0° to 3° (figure 1). The result of the load pressure on the specimen and the self-balancing tendency of the gyrotory axis keep the mould against two roller bearings placed on 120° at the rear, leaving the front access and the entire front of the machine completely free.

The gyrotory motion of the specimen is generated by the rotation of the mould around its own axis. An external observer sees the mould rotating around its own inclined axis on the pre-set gyrotory angle (figure 2A). However, if the observer was positioned at the specimen centre, he would see the gyrotory motion of the specimen itself (figure 2B).

How does this tie in with Galileo?

An example of the orbital motion is what we notice when we stand on earth. We see the sun rotating around the earth, when in fact the opposite is true: the earth is rotating around itself (and around the sun). Hence Galileo's famous exclamation: **"And yet it moves."**

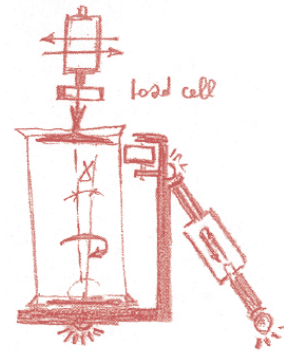

Figure 1

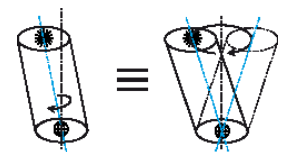

Figure 2A

Figure 2B

"Orbital Motion" Main Benefits

Much higher performance than standard requirements

The simple rotation of the mould around its own inclined axis on the pre-set gyrotory angle ensures a precise and regular motion, maintaining the gyrotory angle constant at all stages of rotation and therefore throughout the test.

The direction of the reaction force to the gyrotory angle is constant. This allows the machine frame to be very simple yet extremely rigid. The result is test parameters which far exceed the Standard requirements and declared in the calibration certificate supplied with the machine.

Simple and lightweight mould design

The gyrotory motion and maintenance of the gyrotory angle do not require sliding and friction-affected mechanisms; instead the mould rests on two roller bearings, which also ensures silent, regular and precise motion. The mould's thickness and hardness conform strictly to standards. It has no bumps or appendages and it is light, easy to handle and hardwearing.

Easy mould placement and removal

Access to the front is completely free. No locking / unlocking operations are required to place or remove the mould. An automatic lifting-lowering mechanism moves the mould on sliding PTFE guides making insertion and or extraction of the mould effortless.

High productivity

The extrusion of the specimen while another test is in progress (and the optional integrated balance) enables continuous use of the machine for high productivity.

Integrated shear resistance measurement

Measurement of shear stress and resisting torque is integrated in the machine.

No accessories are required, thus avoiding any gyrotory angle inaccuracies.

Intuitive Software and Smart Controller

Galileo systems include a smart controller with a wide 7" 16:9 color touch screen control panel. An intuitive and user friendly graphical interface with clear, high contrast design pictograms allows for:

- User input of test parameters, choosing from preset pattern related to relevant standards or user customizable patterns. The servo-controlled operation of the machine allows vertical stress, rate of gyration and gyratory angle* to be quickly modified from the control panel or PC.
- Displaying and plotting either:
 - ▶ **height** ▶ **load** ▶ **density** ▶ **shear stress**
 - ▶ **angle** ▶ **compaction energy** against gyratory cycles in real time. Test data may be stored and retrieved or transferred to other software analysis packages.
- Calibrating of transducers with a highly accurate interpolation to assure the most precise data acquisition
- Diagnostic features to quickly check all the machine devices; moreover, the LAN/Ethernet communications port allows for direct remote connection via the intranet or internet for an immediate diagnostic analysis from manufacturer.

The software includes a wizard guided mode to help and assist the operator throughout the compaction procedure steps.

***Research version only**

Parameters menu

User selectable parameters, for standard and custom tests:

- Four preset pattern related to EN 12697-31, AASHTO T312 and ASTM D6925 standards
- Six user customizable patterns:
 - Vertical load and gyration rate
 - Number of gyrations
 - Target density (or vertical height)
 - Angle (only for Galileo Research)

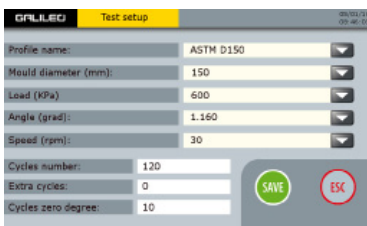

Calibration menu

Accurate calibration of transducers with six (or more) interpolation points in order to achieve certification far exceeding requirements of the international standards.



Test menu

Real time graphical representation of the transducers readings:

- Height
- Density
- Angle
- Shear stress (optional for Galileo standard)
- Compaction energy (optional for Galileo standard)

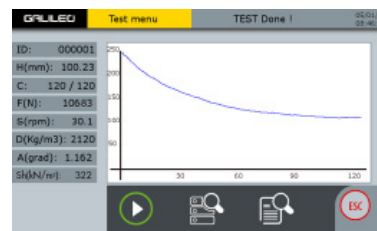

Diagnostic menu

Quickly checks all electronic components and devices such as Load cell / Displacement transducers / Servodrive.

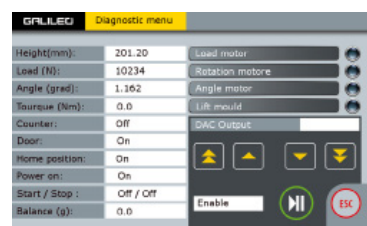

Accessories

Our cylinder moulds and distance plates are suitable for all our gyratory compactors, Galileo, Galileo Research and Gyrocomp.

Made from special alloy steel, hardened to 53-55 HRC, internally ground, Ra less than 1µm, fully conforming to EN 12697-31 and exceeding ASTM D6925 and AASHTO T312.



78-PV0250/10, 150mm dia. mould with holes for bituminous emulsion cold mix compaction



78-PV0250/6, 76-PV0250/5, 78-PV0250/4, 78-PV0250/3, 78-PV0250/2

Cylinder Moulds

78-PV0250/2

Cylinder mould, 150mm diameter. Complete with top and bottom plates.

78-PV0250/5

Cylinder mould, 100mm diameter. Complete with top and bottom plates.

78-PV0250/8

Perforated cylinder mould, 100mm diameter, with holes for cold mix compaction. Complete with top and bottom plates.

78-PV0250/10

Perforated cylinder, 150mm diameter, with holes for cold mix compaction. Complete with top and bottom plates.

Distance Plates

78-PV0250/3

Distance plate, 150mm diameter, 50 mm high, for preparing short samples.

78-PV0250/6

Distance plate, 100mm diameter, 38 mm high, for preparing short samples.

Compacting Accessories

78-PV0250/4

100mm diameter specimen platens, including 100mm height calibration device.

Internal Angle Measurement Apparatus

78-PV0255

ILS Internal angle measurement apparatus (for detailed information, please refer to page 45 of the IPC Global | Controls Group catalogue).



ILS during calibration procedure



All our Gyratory compactors are verified and calibrated with 78-PV0255 ILS apparatus.

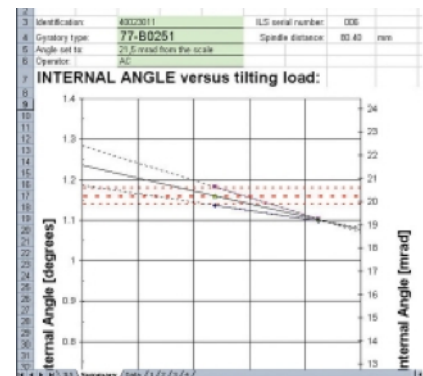

Calibration certificate obtained with the 78-PV0255 ILS apparatus, using the Macro

Specifications

Technical Specifications

Model	Galileo 78-PV20G0X	Galileo Research 78-PV20R0X
Consolidation pressure	10 – 1,000kPa for 150mm diam. 25 – 2,200 kPa for 100mm diam.	10 – 1,000 kPa for 150mm diam. 25 – 2,200kPa for 100 mm diam.
Gyratory motion and vertical load	Electromechanical EmS	Electromechanical EmS
Angle adjustment	Manual	Automatically controlled through PC software or touch screen, with EmS Electromechanical Servoactuation
Gyratory angle range	0 – 3° ±0.01	0 – 3° ±0.005
Gyratory angle measurement	Angle measured and displayed during test	Angle measured and displayed during test plus closed loop control
Traceable ACCREDIA Certificate conforming to ASTM D6925 and ASHTO T312/TP4†	Included	Included
Traceable ACCREDIA Certificate conforming to EN 12697-10 and EN 12697-31†	Optional	Optional
Zero angle at the end of the test	No	Yes (automatic procedure, user selectable)
Speed of gyration	5 – 60 rpm (120 on request)	5 – 60 rpm (120 on request)
Number of gyrations	0 – 9,999	0 – 9,999
Integrated Shear measurement	Yes (optional)	Yes
Moulds dimensions	100 and 150mm diam., 250 mm height.	100 and 150mm diam., 250mm height.
User interface	7" 16:9 Touch screen color display (PC for data analysis)	7" 16:9 Touch screen color display (PC for data analysis)
Connection	LAN – Ethernet	LAN – Ethernet
PC Software	Available as option	Included
Extruder	Available as option (electromechanical)	Included (electromechanical)
Balance	Available as option with an accuracy of 1g	Available as option with an accuracy of 1g
Minimum specimen height	50mm	50mm
Maximum specimen height	Up to 200mm depending on mix type	Up to 200mm depending on mix type
Height accuracy	Better than 0,1mm	Better than 0,1mm
Suitable for water pouring test	Yes	Yes
Suitable for concrete/ cement testing	Yes (on request)	Yes (on request)
Dimensions (w x d x h)	480 x 900 x 2,150mm	480 x 900 x 2,150mm
Weight approx.	400kg	420kg

† ACCREDIA CALIBRATION CERTIFICATE

CONTROLS S.p.A. is accredited as Calibration Centre LAT 092 for the calibration and verification of force transfer on compression machines in accordance to EN 12390-4:2000 and EN-ISO7500-1:2018. ACCREDIA is a signatory of the ILAC-MRA (International Laboratory Accreditation Cooperation – Mutual Recognition Arrangement), meaning calibration certificates with the Accredia mark are recognized and valid worldwide.

The accreditation bodies that are signatories to the ILAC MRA for the relevant accreditation activities will accept the results of each other's accredited laboratories and inspection bodies and programs provided by PTPs (Proficiency Testing Providers).

Standard requirements

Below are the most critical parameters specified in the main International Standards & performance available from Galileo compactors.

Standard requirement	EN 12697-31	ASTM D6925 AASHTO T312	Galileo performance
Internal angle (stability factor)	0.82±0.02°	1.16±0.02°	EN 0.82±0.01° ASTM 1.16±0.01° Research EN 0.82±0.005° ASTM-AASHTO 1.16±0.005°
Parallelism factor $\delta TB = ITA - IBA$	< 0.10°	Not required	< 0.04°
Full rotation factor (δ max-min)	< 0.05°	Not required	< 0.01°
Deflection factor (δ Ih = IEA240 - IEA425)	< 0.10°	Not required	< 0.070° Research < 0.060°
Vertical pressure or force precision	±250N (Ann.A) 600±18 kPa (B C)	600±18 kPa	< 2% target load

Ordering information

Please see IPC Global Advanced Pavements Testing Systems catalogue and www.controls-group.com.

78-PV20G02

Galileo full EmS Gyratory Compactor, 230V, 50/60Hz, 1ph.

78-PV20G04

Galileo full EmS Gyratory Compactor, 110V, 60Hz, 1ph.

78-PV20R02

Galileo Research, full EmS Gyratory Compactor including integrated extruder, shear measurement, EmS motorized regulation of the gyratory angle and displayed on the control panel, PC software for data analysis. 230V, 50/60Hz, 1ph.

78-PV20R04

Galileo Research, full EmS Gyratory Compactor including integrated extruder, shear measurement, EmS motorized regulation of the gyratory angle and displayed on the control panel, PC software for data analysis. 110V, 60Hz, 1ph.

Options for Galileo 78-PV20G0X

78-PV20UP1

Shear measurement system. (to be specified at time of order)

78-PV20UP2

Integrated electromechanical extruder. (to be specified at time of order)

78-PV20/SOF

PC software for Galileo

Options for both versions

78-PV20UP3

Electronic balance, 30kg. cap., 1g resolution, to weight the sample and calculate the density.

78-PV20UP4

Traceable ACCREDIA certificate conforming to EN12697-31 Ann. B.

IPC Global Customer Care

IPC Global is the Advanced Pavement Testing Division of CONTROLS. As one of the longest established manufacturing companies in the world of Construction Materials Testing solutions, we are dedicated to supplying high quality, accurate, affordable, easy to use systems.

As a valued customer of CONTROLS, you will receive continuous, expert support and advice for your IPC Global equipment. Furthermore, we can offer full installation and training in the correct operation of your equipment.

For support from our expert Customer Care Team, contact your local CONTROLS office / distributor or email customercare@controls-group.com.

For more information, please visit www.controls-group.com.

CONTROLS

Italy (HEAD OFFICE)

t +39 02 92184 1

f +39 02 92103 333

e sales@controls-group.com

www.controls-group.com

France

info-fr@controls-group.com

Mexico

info-mx@controls-group.com

Poland

info-pl@controls-group.com

UK

info-uk@controls-group.com

USA

info-usa@controls-group.com